

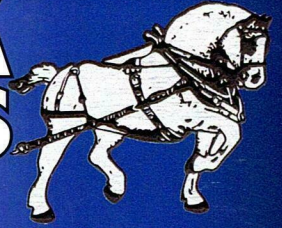

**REAL**

**WORK  
HORSES  
FROM TENNESSEE**



**101 Series  
3-Roll Pinch Pyramid  
Hydraulic  
Plate Bending  
Machines**

**Waldemar Design & Machine LLC**

900 Highland Drive  
Spencer, TN 38585  
931-946-8474

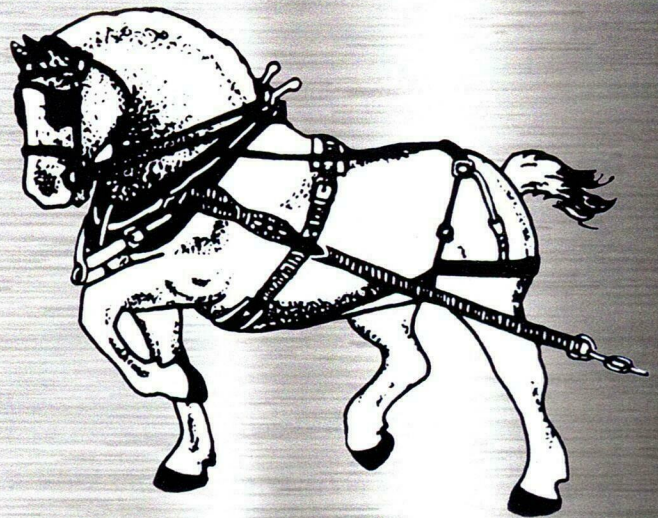

January 2020

# 101 Series Plate Bending Machines



**101-8-4 Plate Roll w/Rolling Console Control**

Because of the design and arrangement of the rolls the pinch pyramid bending roll is a very versatile plate roll. Because of the large openings between the rolls symmetrical structural sections can be rolled without additional attachments, square and rectangle tubing, channel leg in/out, I-beam on flange, and fabricated panels.

In the forming operation both the leading and trailing edges can be performed with one entry of the workpiece into the machine. This eliminates the necessity of manipulating and turning the workpiece for a double entry as is required on an initial pinch type machine.

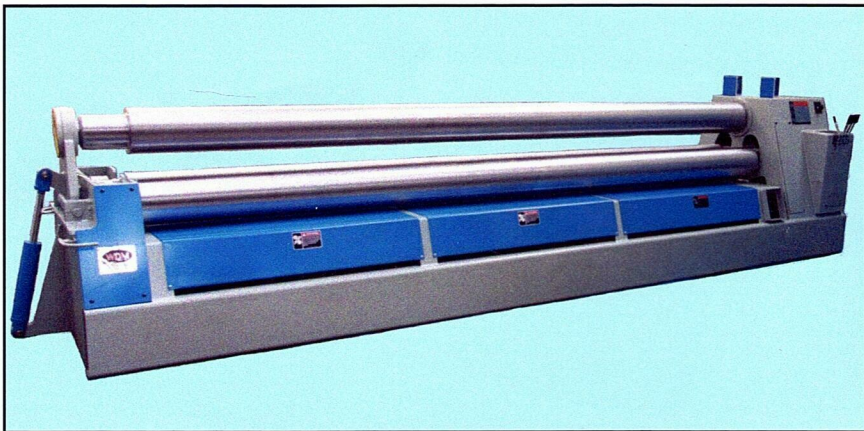

**101-8-16 w/Polished Rolls, Manual Hydraulic Valves, & Long Length to Roll Architectural Components**



**101-6-6 Plate Roll w/Rotation Foot Switch and Manual Hydraulic Valves**

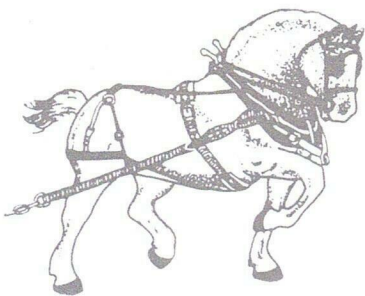

**101-6-2 w/Hardened Only Rolls, Manual Hydraulic Valves and Rotation Foot Switch for rolling clutch and brake bands for Drag Lines**

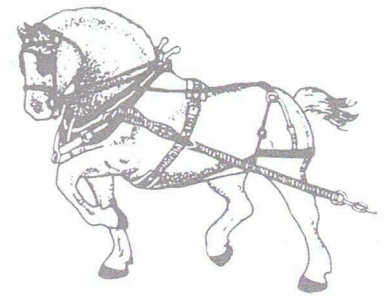

# Standard Features

## ROLLS

All the rolls are accurately machined from steel bars or forgings dependent on size. They are crowned to compensate for deflection during forming pressures, assuring accurate cylinders and workpieces. The rolls turn on sealed spherical roller bearings.

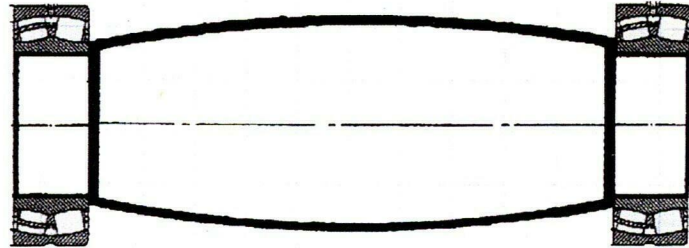
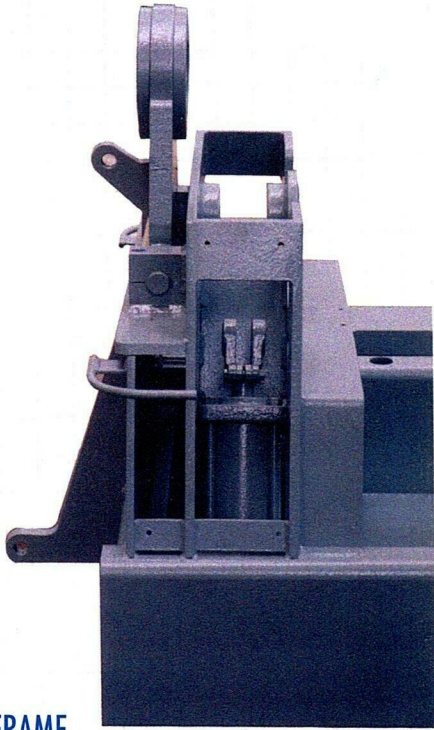

## FRAME

All our machines start with a robust frame constructed from heavy structural sections and steel plates using good welding practices. They are accurately machined to support all the components. In most cases the hydraulic reservoir is integrated into the frame.

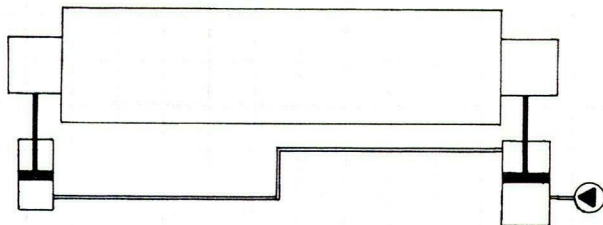

## ROLL SUPPORT AND ADJUSTMENT

The bearings that hold the rolls are supported on a set of master and slave hydraulic cylinders with very effective seals and travel in a radial path. This system has a trim function to put an angle into the roll for rolling cones or dissimilar sections.

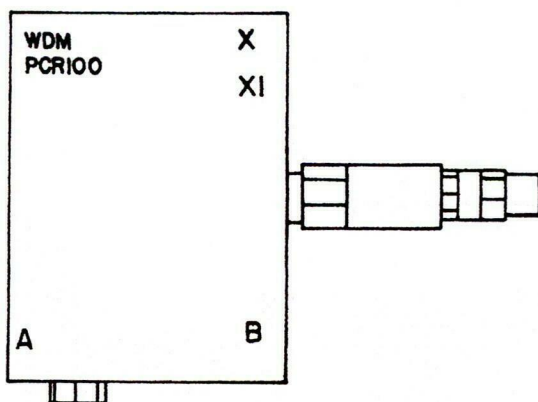

## BETA 3 PENDANT CONTROL

The Beta 3 is a pendant control mounted in a fiberglass enclosure that's encircled by a stainless steel hand rail. Push buttons control near and far roll up/down position and roll rotation. Two LED readouts show the up/down position of the near and far roll. An electronic speed control dial controls the system speed. An E-stop is located on top of the enclosure. Main motor start/stop and dropend up/down are in their own enclosure, mounted on the machine housing. This control comes with a roll around stand to hold the pendant, converting it into a rolling console. This control is recommended for job shops with part batches of up to 10 pieces.

## RESTORING PARALLELISM OF ROLLS

Restoring parallelism of rolls is accomplished by a special valve arrangement designed by WDM which is activated when the roll is lowered to the bottom and held momentarily until all movement ceases. Roll is then parallel with top roll.

# Capacity Ratings and Specifications For WDM 101 Series Pinch Pyramid Plate Rolls

MODEL	1.5x TOP ROLL DIA. PREBEND CAPACITY	4X TOP ROLL DIA. RATED CAPACITY	TOP ROLL Ø	HORSE POWER	SIZE L x W x H	WEIGHT
101-5-4	0.16 X 48	0.19 X 48	5	3	88 X 35 X 37	2,700
101-6-4	0.31 X 48	0.37 X 48	6	5	91 X 35 X 40	3,900
101-7-4	0.38 X 48	0.45 X 48	7	5	91 X 35 X 40	5,300
101-8-4	0.50 X 48	0.60 X 48	8	7.5	98 X 44 X 47	6,900
101-9-4	0.63 X 48	0.75 X 48	9	10	98 X 44 X 47	8,700
101-10-4	0.72 X 48	0.86 X 48	10	10	102 X 50 X 51	10,700
101-11-4	0.88 X 48	1.05 X 48	11	15	102 X 50 X 51	13,000
101-12-4	1.06 X 48	1.26 X 48	12	20	104 X 58 X 57	16,000
A101-13-4	1.25 X 48	1.49 X 48	13	25	104 X 58 X 57	18,000
A101-14-4	1.40 X 48	1.67 X 48	14	40	125 X 70 X 65	21,000
A101-15-4	1.63 X 48	1.94 X 48	15	50	125 X 70 X 65	24,000
A101-16-4	1.75 X 48	2.08 X 48	16	50	146 X 76 X 80	27,000
A101-17-4	2.00 X 48	2.38 X 48	17	60	146 X 76 X 80	31,000
A101-18-4	2.25 X 48	2.68 X 48	18	60	152 X 86 X 91	35,000
A101-19-4	2.50 X 48	2.98 X 48	19	75	152 X 86 X 91	39,000
A101-20-4	2.75 X 48	3.27 X 48	20	75	158 X 96 X 100	43,000
101-5-5	0.14 X 60	0.17 X 60	5	3	103 X 35 X 37	3,000
101-6-5	0.27 X 60	0.32 X 60	6	5	106 X 35 X 40	4,000
101-7-5	0.33 X 60	0.39 X 60	7	5	106 X 35 X 40	6,000
101-8-5	0.44 X 60	0.52 X 60	8	7.5	118 X 44 X 47	7,000
101-9-5	0.50 X 60	0.60 X 60	9	10	118 X 44 X 47	9,000
101-10-5	0.63 X 60	0.75 X 60	10	10	124 X 50 X 51	12,000
101-11-5	0.79 X 60	0.94 X 60	11	15	124 X 50 X 51	14,000
101-12-5	0.94 X 60	1.12 X 60	12	20	126 X 58 X 57	17,000
A101-13-5	1.06 X 60	1.26 X 60	13	25	126 X 58 X 57	20,000
A101-14-5	1.25 X 60	1.49 X 60	14	40	137 X 70 X 65	23,000
A101-15-5	1.44 X 60	1.71 X 60	15	50	137 X 70 X 65	26,000
A101-16-5	1.57 X 60	1.87 X 60	16	50	158 X 76 X 80	30,000
A101-17-5	1.75 X 60	2.08 X 60	17	60	158 X 76 X 80	34,000
A101-18-5	2.00 X 60	2.38 X 60	18	60	164 X 86 X 91	38,000
A101-19-5	2.18 X 60	2.59 X 60	19	75	164 X 86 X 91	42,000
A101-20-5	2.32 X 60	2.76 X 60	20	75	170 X 96 X 100	47,000
101-5-6	0.10 X 72	0.12 X 72	5	3	112 X 35 X 37	3,000
101-6-6	0.22 X 72	0.26 X 72	6	5	115 X 35 X 40	5,000
101-7-6	0.28 X 72	0.33 X 72	7	5	115 X 35 X 40	6,000
101-8-6	0.38 X 72	0.45 X 72	8	7.5	122 X 44 X 47	8,000
101-9-6	0.41 X 72	0.49 X 72	9	10	122 X 44 X 47	10,000
101-10-6	0.56 X 72	0.67 X 72	10	10	126 X 50 X 51	13,000
101-11-6	0.69 X 72	0.82 X 72	11	15	126 X 50 X 51	15,000
101-12-6	0.81 X 72	0.96 X 72	12	20	128 X 58 X 57	18,000
A101-13-6	1.00 X 72	1.19 X 72	13	25	128 X 58 X 57	21,000
A101-14-6	1.13 X 72	1.34 X 72	14	40	149 X 70 X 65	25,000
A101-15-6	1.25 X 72	1.49 X 72	15	50	149 X 70 X 65	29,000
A101-16-6	1.38 X 72	1.64 X 72	16	50	170 X 76 X 80	32,000
A101-17-6	1.50 X 72	1.79 X 72	17	60	170 X 76 X 80	37,000
A101-18-6	1.63 X 72	1.94 X 72	18	60	176 X 86 X 91	41,000
A101-19-6	1.75 X 72	2.08 X 72	19	75	176 X 86 X 91	46,000
A101-20-6	1.88 X 72	2.24 X 72	20	75	182 X 96 X 100	51,000
A101-21-6	2.00 X 72	2.38 X 72	21	75*	182 X 96 X 100	56,000
A101-22-6	2.25 X 72	2.68 X 72	22	75*	191 X 104 X 109	62,000
A101-23-6	2.50 X 72	2.98 X 72	23	75*	191 X 104 X 109	67,000
A101-24-6	2.75 X 72	3.27 X 72	24	75*	198 X 114 X 119	73,000

\* = THESE UNITS LIMITED TO 75 HP AT REDUCED ROLLING SPEED. LARGER HP AVAILABLE IF DESIRED.

A = These models manufactured by Athens / Wildcat Gear (See back page)

## NOTES

Capacity is based on 40,000 p.s.i. yield strength material. These machines are also available in 2, 3, 18, and 20 feet and longer lengths. Please inquire for price and availability and to verify dimensions and specifications.

*We reserve the right to make changes in design and specifications without obligation or notification.*

## WARNING

We have incorporated safety features into this machine. It is the responsibility of the owner / employer to provide point-of-operation guards or operating procedures necessary to adequately protect operator and ensure that it is only operated by qualified personnel in a safe manner.

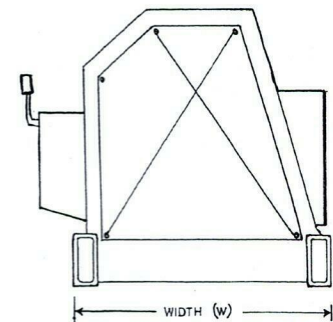
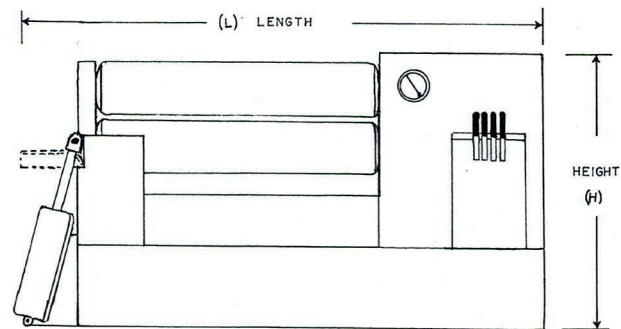

# Capacity Ratings and Specifications For WDM 101 Series Pinch Pyramid Plate Rolls

MODEL	1.5x TOP ROLL DIA. PREBEND CAPACITY	4X TOP ROLL DIA. RATED CAPACITY	TOP ROLL Ø	HORSE POWER	SIZE L x W x H	WEIGHT
101-5-8	0.06 X 96	0.07 X 96	5	3	136 X 35 X 37	4,000
101-6-8	0.14 X 96	0.17 X 96	6	5	139 X 35 X 40	5,000
101-7-8	0.18 X 96	0.21 X 96	7	5	139 X 35 X 40	7,000
101-8-8	0.25 X 96	0.30 X 96	8	7.5	146 X 44 X 47	9,000
101-9-8	0.31 X 96	0.37 X 96	9	10	146 X 44 X 47	12,000
101-10-8	0.41 X 96	0.49 X 96	10	10	150 X 50 X 51	15,000
101-11-8	0.52 X 96	0.62 X 96	11	15	150 X 50 X 51	18,000
101-12-8	0.63 X 96	0.75 X 96	12	20	152 X 58 X 57	21,000
A101-13-8	0.73 X 96	0.87 X 96	13	25	152 X 58 X 57	25,000
A101-14-8	0.86 X 96	1.02 X 96	14	40	173 X 70 X 65	29,000
A101-15-8	0.98 X 96	1.17 X 96	15	50	173 X 70 X 65	33,000
A101-16-8	1.06 X 96	1.26 X 96	16	50	194 X 76 X 80	38,000
A101-17-8	1.27 X 96	1.51 X 96	17	60	194 X 76 X 80	43,000
A101-18-8	1.42 X 96	1.69 X 96	18	60	200 X 86 X 91	48,000
A101-19-8	1.58 X 96	1.88 X 96	19	75	200 X 86 X 91	53,000
A101-20-8	1.77 X 96	2.11 X 96	20	75	206 X 96 X 100	59,000
A101-21-8	1.97 X 96	2.34 X 96	21	75*	206 X 96 X 100	65,000
A101-22-8	2.16 X 96	2.57 X 96	22	75*	215 X 104 X 109	71,000
A101-23-8	2.31 X 96	2.75 X 96	23	75*	215 X 104 X 109	78,000
A101-24-8	2.55 X 96	3.03 X 96	24	75*	222 X 114 X 119	85,000
101-5-10	0.05 X 120	0.06 X 120	5	3	160 X 35 X 37	4,000
101-6-10	0.09 X 120	0.11 X 120	6	5	163 X 35 X 40	6,000
101-7-10	0.13 X 120	0.15 X 120	7	5	163 X 35 X 40	8,000
101-8-10	0.17 X 120	0.20 X 120	8	7.5	170 X 44 X 47	11,000
101-9-10	0.23 X 120	0.27 X 120	9	10	170 X 44 X 47	14,000
101-10-10	0.31 X 120	0.37 X 120	10	10	174 X 50 X 51	17,000
101-11-10	0.39 X 120	0.46 X 120	11	15	174 X 50 X 51	20,000
101-12-10	0.50 X 120	0.60 X 120	12	20	176 X 58 X 57	24,000
A101-13-10	0.59 X 120	0.70 X 120	13	25	176 X 58 X 57	28,000
A101-14-10	0.69 X 120	0.82 X 120	14	40	197 X 70 X 65	33,000
A101-15-10	0.80 X 120	0.95 X 120	15	50	197 X 70 X 65	38,000
A101-16-10	0.89 X 120	1.06 X 120	16	50	218 X 76 X 80	43,000
A101-17-10	1.03 X 120	1.23 X 120	17	60	218 X 76 X 80	48,000
A101-18-10	1.16 X 120	1.38 X 120	18	60	224 X 86 X 91	54,000
A101-19-10	1.28 X 120	1.52 X 120	19	75	224 X 86 X 91	60,000
A101-20-10	1.42 X 120	1.69 X 120	20	75	230 X 96 X 100	67,000
A101-21-10	1.51 X 120	1.80 X 120	21	75*	230 X 96 X 100	74,000
A101-22-10	1.73 X 120	2.06 X 120	22	75*	239 X 104 X 109	81,000
A101-23-10	1.89 X 120	2.25 X 120	23	75*	239 X 104 X 109	89,000
A101-24-10	2.05 X 120	2.44 X 120	24	75*	246 X 114 X 119	96,000

\* = THESE UNITS LIMITED TO 75 HP AT REDUCED ROLLING SPEED. LARGER HP AVAILABLE IF DESIRED.

A = These models manufactured by Athens / Wildcat Gear (See back page)

## STANDARD FEATURES

- 1045 Steel rolls machined to 63 micro inches
- Total hydraulic operation
- Instant start-stop-reverse
- Roll speed infinitely variable 0 - 22 FPM (smaller machine), 0 - 12 FPM (larger machine)
- 3 Roll drive
- Electrics to NFPA-79 specifications  
12/24 VDC or 120 VAC control circuit
- 3 Phase 230/460 Volts, 60 HZ
- Overload protected
- TEFC motor
- Quiet hydraulic system
- Haze gray epoxy and blue enamel finish (V.O.C. compliant)
- Athens units (Prefix "A") are tan epoxy and brown enamel finish (V.O.C. compliant)
- Sealed spherical roller bearings on all main points
- 1 Squaring Groove in far roll
- Rolls tilt for cone rolling
- Rolls driven through efficient spur gear drives or planetary speed reducers
- Dial pointer type roll position indicators
- Hydraulically actuated drop-end
- Accurately machined, compact, streamlined, all welded steel frame
- 1 year warranty
- Made in Spencer, TN, USA using components from American and worldwide companies

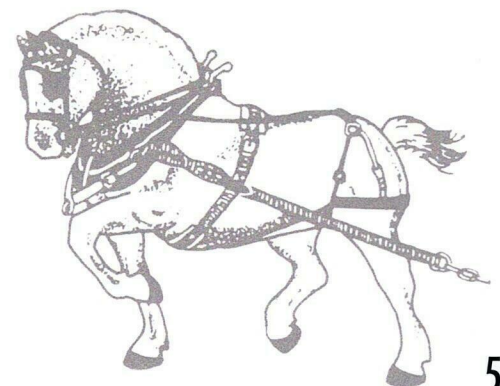

# Capacity Ratings and Specifications

## For WDM 101 Series Pinch Pyramid Plate Rolls

MODEL	1.5x TOP ROLL DIA. PREBEND CAPACITY	4X TOP ROLL DIA. RATED CAPACITY	TOP ROLL Ø	HORSE POWER	SIZE L x W x H	WEIGHT
101-5-12	0.04 X 144	0.05 X 144	5	3	184 X 35 X 37	5,000
101-6-12	0.06 X 144	0.07 X 144	6	5	187 X 35 X 40	7,000
101-7-12	0.09 X 144	0.11 X 144	7	5	187 X 35 X 40	8,000
101-8-12	0.14 X 144	0.17 X 144	8	7.5	194 X 44 X 47	12,000
101-9-12	0.17 X 144	0.20 X 144	9	10	194 X 44 X 47	15,000
101-10-12	0.23 X 144	0.27 X 144	10	10	198 X 50 X 51	19,000
101-11-12	0.28 X 144	0.33 X 144	11	15	198 X 50 X 51	23,000
101-12-12	0.38 X 144	0.45 X 144	12	20	200 X 58 X 57	27,000
A101-13-12	0.41 X 144	0.49 X 144	13	25	200 X 58 X 57	32,000
A101-14-12	0.55 X 144	0.65 X 144	14	40	221 X 70 X 65	37,000
A101-15-12	0.63 X 144	0.75 X 144	15	50	221 X 70 X 65	42,000
A101-16-12	0.75 X 144	0.89 X 144	16	50	242 X 76 X 80	48,000
A101-17-12	0.81 X 144	0.96 X 144	17	60	242 X 76 X 80	54,000
A101-18-12	0.94 X 144	1.12 X 144	18	60	248 X 86 X 91	61,000
A101-19-12	1.00 X 144	1.19 X 144	19	75	248 X 86 X 91	68,000
A101-20-12	1.09 X 144	1.30 X 144	20	75	254 X 96 X 100	75,000
A101-21-12	1.28 X 144	1.52 X 144	21	75*	254 X 96 X 100	83,000
A101-22-12	1.41 X 144	1.68 X 144	22	75*	263 X 104 X 109	91,000
A101-23-12	1.53 X 144	1.82 X 144	23	75*	263 X 104 X 109	99,000
A101-24-12	1.66 X 144	1.98 X 144	24	75*	272 X 114 X 119	108,000
A101-9-16	0.13 X 192	0.15 X 192	9	10	239 X 44 X 47	18,000
A101-10-16	0.16 X 192	0.19 X 192	10	10	246 X 50 X 51	23,000
A101-11-16	0.20 X 192	0.24 X 192	11	15	246 X 50 X 51	28,000
A101-12-16	0.25 X 192	0.30 X 192	12	20	248 X 58 X 57	33,000
A101-13-16	0.30 X 192	0.36 X 192	13	25	248 X 58 X 57	39,000
A101-14-16	0.36 X 192	0.43 X 192	14	40	269 X 70 X 65	45,000
A101-15-16	0.42 X 192	0.50 X 192	15	50	269 X 70 X 65	51,000
A101-16-16	0.50 X 192	0.60 X 192	16	50	290 X 76 X 80	58,000
A101-17-16	0.58 X 192	0.69 X 192	17	60	290 X 76 X 80	66,000
A101-18-16	0.67 X 192	0.80 X 192	18	60	296 X 86 X 91	74,000
A101-19-16	0.78 X 192	0.93 X 192	19	75	296 X 86 X 91	82,000
A101-20-16	0.86 X 192	1.02 X 192	20	75	302 X 96 X 100	91,000
A101-21-16	0.94 X 192	1.12 X 192	21	75*	302 X 96 X 100	101,000
A101-22-16	1.06 X 192	1.26 X 192	22	75*	311 X 104 X 109	110,000
A101-23-16	1.16 X 192	1.38 X 192	23	75*	311 X 104 X 109	130,000
A101-24-16	1.25 X 192	1.49 X 192	24	75*	320 X 114 X 119	150,000

\* = THESE UNITS LIMITED TO 75 HP AT REDUCED ROLLING SPEED. LARGER HP AVAILABLE IF DESIRED.

A = These models manufactured by Athens / Wildcat Gear (See back page)

### STANDARD OPTIONS

- Hardened and polished rolls 28-32 Rc 32 RMS
- Hardened and polished rolls 55-60 Rc (case hardened) 32 RMS
- Other alloys, chrome plating and other finishes are available, inquire
- Additional squaring grooves in lower rolls
- Circular grooves in rolls for rolling rods or sheets with wire edges 3/8, 1/2, and 5/8
- Other special circular grooves for extrusions, etc.
- Forward & reverse guarded foot pedal for roll rotation
- Cone attachment
- Heavy duty cone attachment
- Side supports
- Overhead supports
- Ejectors
- DRO for roll position instead of dial pointer indicator
- Same as above on both ends of rolls
- DRO with 2-preset stops for roll position indicators and control
- Same as above with an additional DRO to show position of outboard end of roll; useful for cone rolling
- DRO length indicator to show length rolled to facilitate forming of flat-radius-flat, ect. type workpiece
- Same as above with 2 presets
- Same as above with 6 presets
- Electric roving pendant control to replace manual valves on machine housing
- Movable console electric control to replace manual valves on machine housing

# Controls

WDM offers a wide range of controls tailored for your unique requirements.

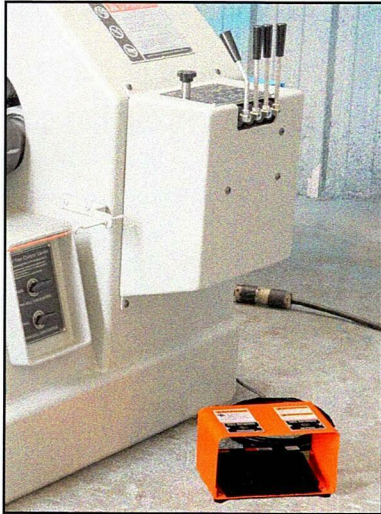

**FOOT SWITCH**

This feature is available for forward and reverse rotation of the rolls, allowing operator to use both hands to manipulate workpiece and can be used on all control styles.



**PRE 3 SEMI-AUTOMATIC FREE STANDING CONTROL**

The Pre 3 semi-automatic free standing rolling console provides digital readouts and 2 presets for each axis (near & far roll). Also included is the LP2 (length position) with readout and 2 presets for the roll rotation. All machine functions are controlled via joystick or push button on the control panel. Motor start/stop, dropend up/down, speed control dial and E-stop is mounted in the panel for easy access. The controls are housed in a heavy duty Nema 12 enclosure with stainless steel guard rail. This popular control provides just enough automation to greatly speed through put, performance, and accuracy. It is easily programmed and can be used as standard or preset type control. In many cases this control increases roll performance 500% or more and is usually all the automation that is required. This control is recommended for part batch sizes from 3 to 100 pieces or more.



**CONE 3 - CONE ROLLING FREE STANDING CONTROL**

The Cone 3 free standing rolling console provides 2 digital readouts showing the position of each end of the 2 lower adjustable rolls.

All machine functions; roll rotation forward and reverse, near and far roll up and down, near and far roll trim up and down, drop end up and down, main electric motor start and stop, emergency stop, and system speed, are controlled from the console.

The controls are housed in a heavy duty Nema 12 enclosure with a stainless steel hand rail.

This control along with an optional cone attachment and hardened and polished rolls make a great cone rolling machine.

**OTHER FEATURES AND VARIATIONS AVAILABLE TO SUIT YOUR INDIVIDUAL NEEDS . . . PLEASE INQUIRE.**

## WDM Users and Suppliers

AEROQUIP CORPORATION - AERO SPACE DIVISION  
 AMERICAN YARD PRODUCTS - LAWN & GARDEN EQUIPMENT  
 APPALACHIAN BOILERS - BOILERS  
 ASTEC - ASPHALT PLANTS  
 BETTS INDUSTRIES - TANK COMPONENTS  
 CARRIER CORPORATION - AIR CONDITIONING  
 CHIEF AGR INDUSTRIAL - AGRICULTURAL EQUIPMENT  
 COOPER LIGHTING - LIGHTING PRODUCTS  
 CORNELL UNIVERSITY  
 DONALDSON/TORIT - AIR FILTRATION  
 DRESSER INDUSTRIES - TURBINE MFG  
 FELDMIER EQUIPMENT - FOOD PROCESSING EQUIPMENT  
 FORD MOTOR - AUTOMOTIVE

**SOME WDM USERS**

GENERAL MOTORS - AUTOMOTIVE  
 GREAT DANE - TRAILERS  
 GREINER ADVANCED MFG. - CUSTOM FAB  
 GSI GROUP - AGRICULTURAL EQUIPMENT  
 HARTZELL FAN - VENTILATION  
 HUTCHINSON MAYRATH - GRAIN HANDLING EQUIPMENT  
 JR METAL PRODUCTS - MANHOLE RISERS  
 JUMP KING - TRAMPOLINES  
 MN DOT DISTRICT 6 - ROAD DEPARTMENT  
 NASA - AEROSPACE  
 NATIONAL STEEL AND SHIPBUILDING - SHIPYARD  
 OLSON INDUSTRIES - AIRPORT LIGHTING PRODUCTS

OXMASTER - CHEMICAL EQUIPMENT  
 PAUL'S FANS - MINE VENTILATION EQUIPMENT  
 PEOBODY TECHTANK - PLASTIC STORAGE EQUIPMENT  
 PORVAIR FILTRATION - FILTRATION  
 QUALITY STEEL - PROPANE TANKS  
 SAMUEL PRESSURE VESSEL GROUP - PRESSURE VESSELS  
 SWECO - FILTRATION SYSTEMS  
 TROXEL TANK - SEMI TRUCK TRAILERS  
 UNION ELETRIC - NUCLEAR GENERATION PLANT  
 US STEEL - MINE  
 UTICA BOILER - RESIDENTIAL HEATING  
 WALKER STAINLESS - FOOD PROCESSING & TRANSPORT  
 WORTHINGTON CYLINDERS - PRESSURE VESSELS

**SOME WDM SUPPLIERS**

ALLEN BRADLEY - ELECTRICS  
 AUBURN GEAR - PLANETARY DRIVES  
 BALDOR - MOTORS  
 CHAR-LYNN/EATON CORP. - LSHT HYDRAULIC MOTORS  
 C-3 CONTROL - ELECTRICAL COMPONENTS  
 CONTINENTAL - HYDRAULIC COMPONENTS  
 EARLE M. JORGENSON - STEEL SUPPLIER

HOFFMAN - ELECTRICAL ENCLOSURES  
 HYDRA FORCE - HYDRAULIC COMPONENTS  
 KURT - HYDRAULIC HOSE & FITTINGS  
 LOCTITE - SEALANTS & ADHESIVES  
 LOVEJOY - COUPLINGS  
 MC GILL - BEARINGS AND CAM FOLLOWERS

PRINCE MANUFACTURING - HYDRAULIC COMPONENTS  
 SKF - BEARINGS AND SEALS  
 SWEDGELOCK - VALVES  
 TNEPEC - PAINTS AND COATINGS  
 TOMPKINS - HYDRAULIC FITTINGS  
 TRADEMARK DESIGNS - NAME PLATES  
 WILDCAT GEAR - GEARS, SPROCKETS, AND DRIVES

# Rolling Procedure

The normal procedure for forming a workpiece on a pinch pyramid roll is illustrated below.

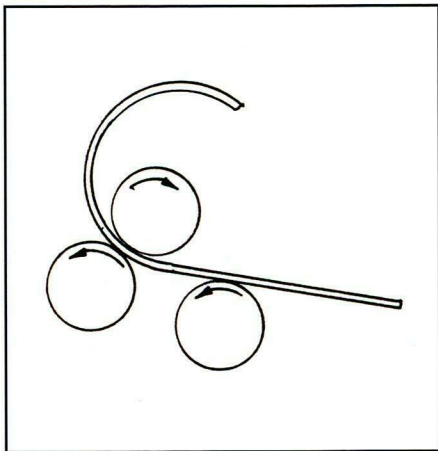

Workpiece is entered into the machine. Far roll is raised to pinch the material. Near roll is raised to the proper position for the radius being performed. Workpiece is rolled to near completion.

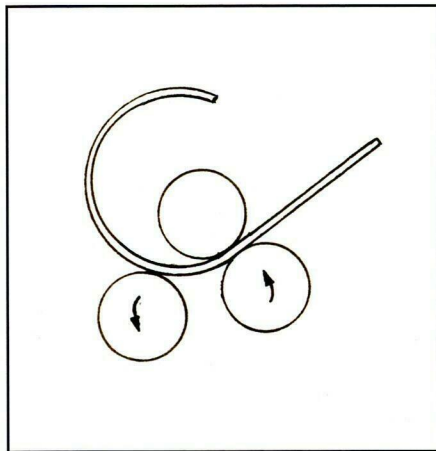

Far roll is lowered. Near roll is raised to pinch the material. Far roll is raised to the proper position for the radius being performed.

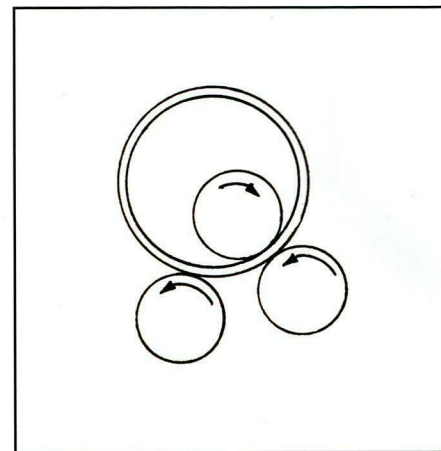

The workpiece is rolled to completion.

The above procedure produces the least amount of flat on the leading and trailing edges. However, to obtain maximum machine capacity, the rolls must be operated in the true pyramid configuration producing a flat on the leading and trailing edges of the workpiece which may be cut off just prior to finish rolling.

## WORKPIECE ACCURACY

In the final analysis, the proof of performance is the acceptability of the finished workpiece. With uniform quality of the workpiece blanks, our machines have historically rolled workpieces within 1/2 of 1% of perfect concentricity.

There are many variables that can affect the accuracy and repeatability either minimally or drastically. These include, but are not limited to, the following: varying material thickness; varying material temper; uneven cross section of material, i.e. wide and narrow profile of workpiece or a workpiece with holes or cutouts; and direction of grain of material.

Many of these variables can be overcome by various means. An important element for success is a knowledgeable operator who understands the characteristics of the material being formed and the various functions of the machine. If the workpiece being formed is anything other than uniform material and cylinders, and you are unsure if your pieces can be rolled practically, please provide us with a drawing or sketch and we will be happy to evaluate it.

## WARRANTY

Waldemar Design & Machine warrants its products to be free from defects in material and workmanship for a period of one year from date of manufacture.

Waldemar's obligation is to replace, free of charge, any defective part of any product that its inspection shows to be defective, including the lowest priced round trip transportation to Waldemar's plant in Spencer, TN, from any point in the 48 contiguous states.

Waldemar shall not be liable for installation and removal expense, loss of time, manufacturing costs, labor, material, loss of profits, or consequential damages direct or indirect, because of defective products. There is no other warranty, express or implied.

## TRAINING

Waldemar Design & Machine strongly encourages the dealer and/or customer to visit our plant upon completion of the machine to receive free training on the machine's operation and maintenance.



# Some Optional Features

Cones can be readily formed using the standard roll tilt feature and one of the optional cone attachments. The cone rolling capacity is 1/3 of the plate capacity (1/3 of the width or 1/3 of the thickness). This attachment consists of a steel sleeve that has composite sleeve bearings which slides onto the reduced diameter portion of the top roll next to the dropend.

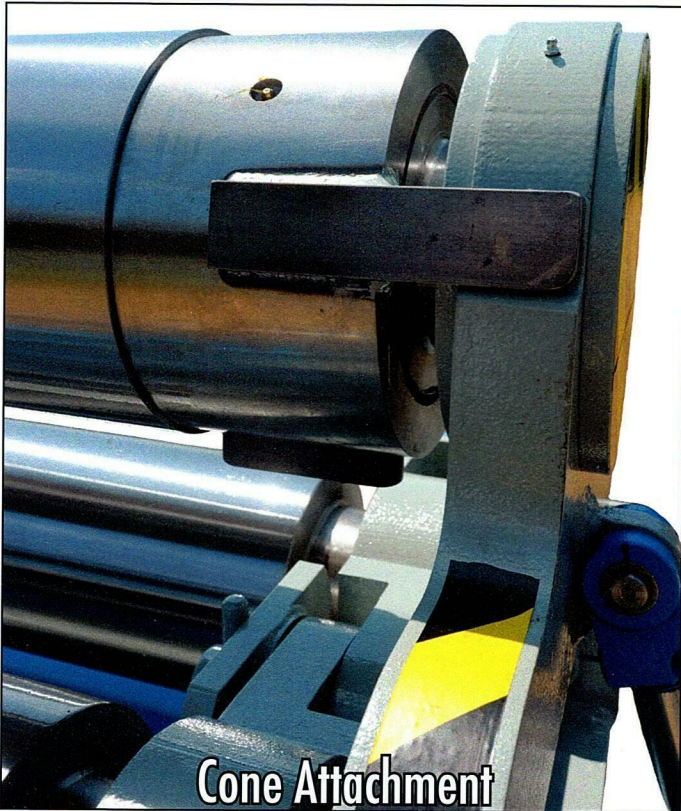

**Cone Attachment**

This style has an indexable and replaceable hardened steel nose. It is locked into position by the dropend and is easily removed when not rolling cones. This style is recommended for occasional cone jobs.

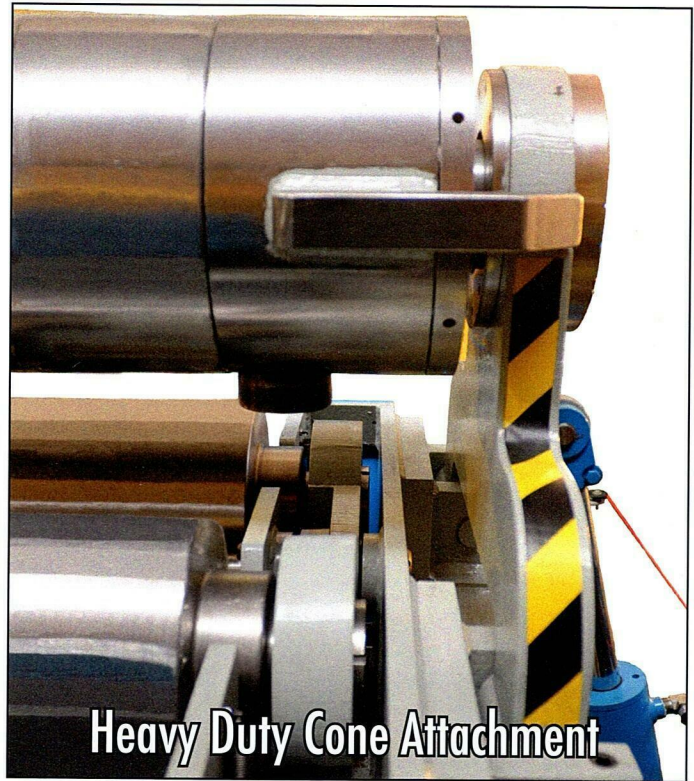

**Heavy Duty Cone Attachment**

This style has a hardened roller nose and is fastened to the top roll with a nut to take the end pressure. It is not easily removed when not needed, but can be rotated 180° to provide unrestricted removal of the work piece. This cone attachment along with hardened and polished rolls and inboard/outboard readouts are recommended for production cone rolling.

## We offer a Wide Range of Work Supports



403-7-8 with standard style side supports.



403-12-12 with custom side supports.

# More Machines by WDM



403-10-12 rolling cell for rolling natural gas tanks for vehicles

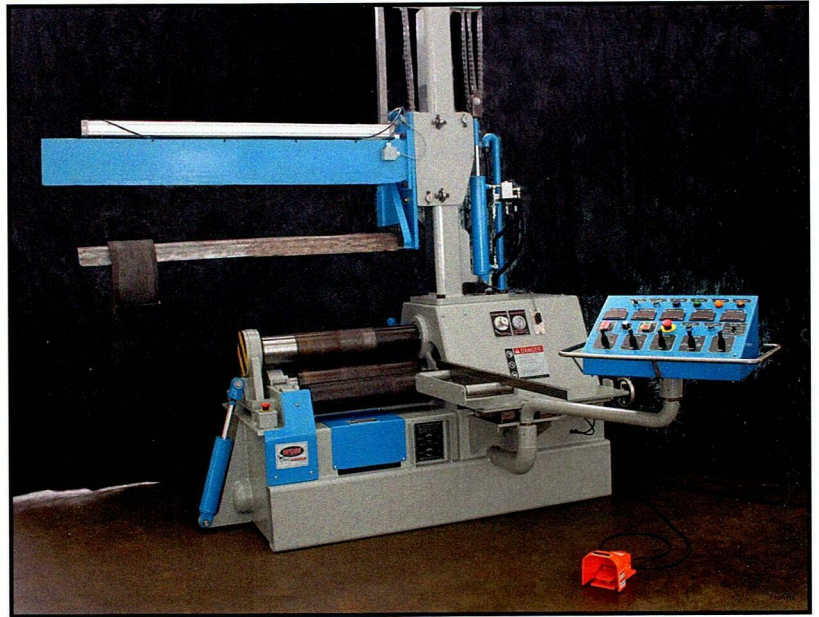

403-8(6)-2 with infeed table and overhead/ejector rolling manhole cover risers

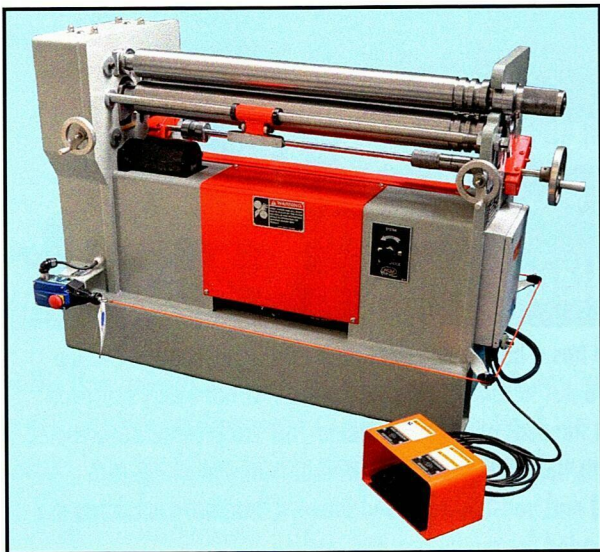

B3.5-36 sheet metal roller with custom color paint

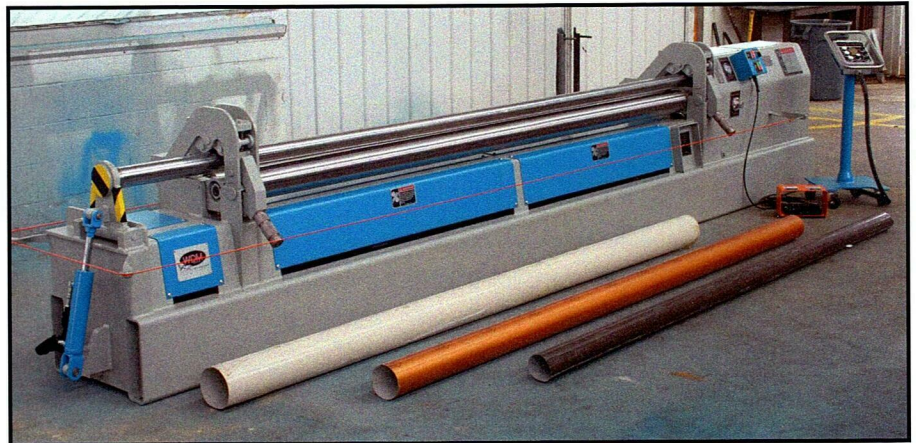

KRR-3.5-120 rigidified top roll initial pinch rolling gutter down spouts



FA-7 flange forming machine making firepit ring inserts

# Some Machines by Athens/Wildcat



*Athens*  
MACHINE BUILDERS



Model A403-22/16-28 w/Infeed table, side & overhead supports specially equipped for cone rolling 1/2 x 28 ft. MS capacity



ABR-2.5-60 Auto Rolling of Duct for Laser Welding

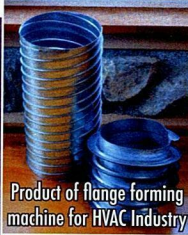

Product of flange forming machine for HVAC Industry

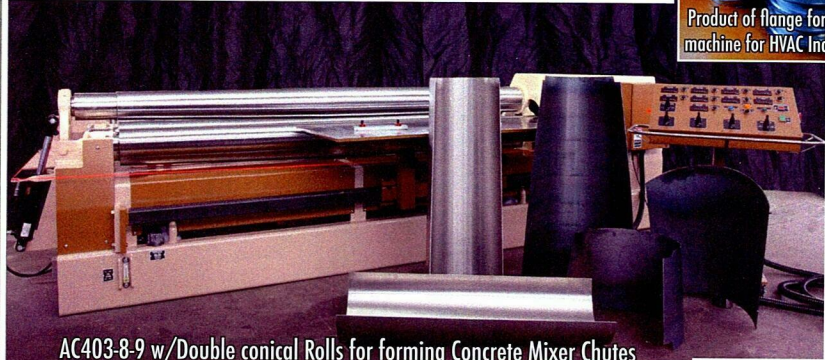

AC403-8-9 w/Double conical Rolls for forming Concrete Mixer Chutes

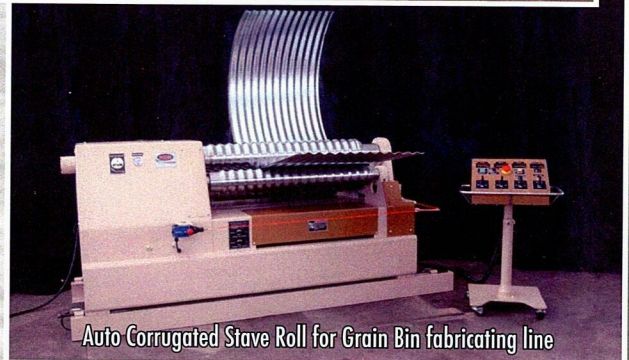

Auto Corrugated Stave Roll for Grain Bin fabricating line

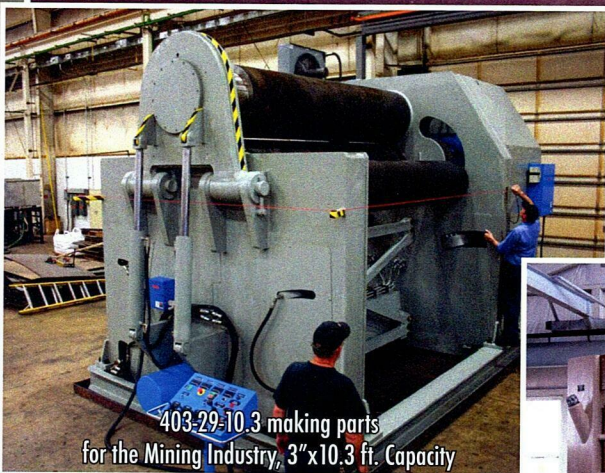

403-29-10.3 making parts for the Mining Industry, 3" x 10.3 ft. Capacity

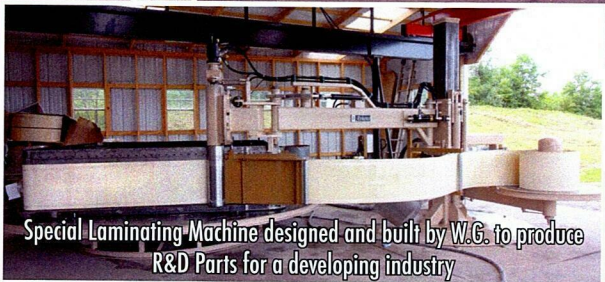

Special Laminating Machine designed and built by W.G. to produce R&D Parts for a developing industry



Vertical Rolls for large diameter Tank Staves 1/2 x 4 ft. capacity

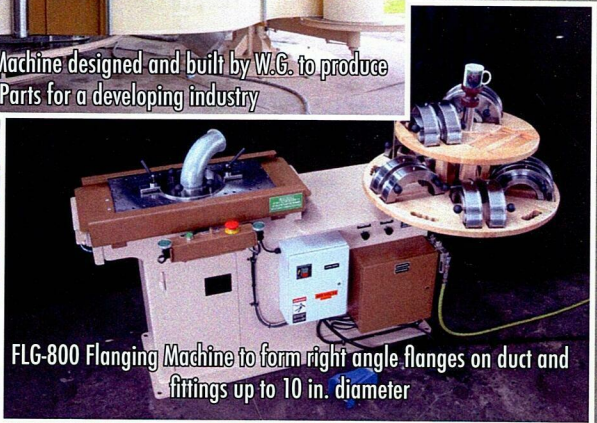

FLG-800 Flanging Machine to form right angle flanges on duct and fittings up to 10 in. diameter

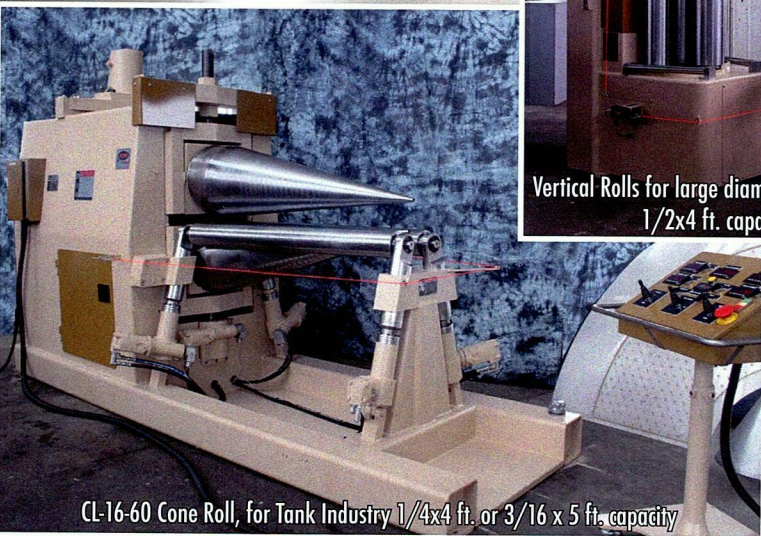

CL-16-60 Cone Roll, for Tank Industry 1/4 x 4 ft. or 3/16 x 5 ft. capacity



Modified Angle Roll Forming Conical Drip Rings for Concrete Mixer

For three generations the family business of Waldemar Design and Machine has been designing and manufacturing metal forming machines for industry small and large. We build these machines in a simple setting exercising serious craftsmanship and integrity. Many of the high quality components are manufactured in our shops in Tennessee, USA, or purchased from domestic or world wide suppliers. Special attention is paid to quality, availability, and durability.

Your satisfaction and the performance of our machines is held in highest regard.

—Owners

## PUBLIC NOTICE

Some distributors sell WDM and Athens products via the Internet. WDM and Athens do not, nor do we have a website, FAX or e-mail service. For direct, personal service and help in solving problems, please contact us at one of the phone numbers below or send inquiries or drawings by mail or courier-collect, FedEx, UPS Red, or other. We will gladly accept courier charges.

### FOR INFORMATION AND HELP —

FOR:

- Standard Machines
- Plate Rolls 12" and smaller rolls
- Angle Rolls to 6 X 6 X 3/4
- Manufacturing Cells
- Other Similar Machines

FOR:

- Cone Rolls
- Special Machines
- Plate Rolls larger than 12" rolls
- Special Forming Systems and Manufacturing cells
- Flange and Head Forming Machines
- Other Similar Machines

\* If you are unsure which company to contact, contact WDM, they will guide your inquiry.



**WALDEMAR DESIGN  
& MACHINE LLC**

**MACHINE TOOL BUILDERS**

MULTI-ROLL PLATE & ANGEL BENDING ROLLS & SYSTEMS  
900 HIGHLAND DRIVE  
SPENCER, TN 38585

**Main Office (931) 946-8474**



**Athens**  
MACHINE BUILDERS

QUALITY MACHINES FOR METAL WORKING

600 Eagle Way • Spencer, TN 38585  
Phone: 931-946-1650 7:00 - 8:00AM & 1:00 - 1:30PM Central Time  
A WILDCAT GEAR COMPANY